



**DIN VENTILATION**

# PRODUCT CATALOGUE

Innovative Air Solutions



Purification



Ventilation and  
Heat Recovery



Cooling/Heating



Dehumidification



T CB



# MANUFACTURING

**Annual production of 300,000 sets of energy recovery ventilators.**

Din Ventilation has its own manufacturing base and R&D center, with skilled assembly lines and test labs there. Besides, we collaborate with multiple reputable domestic HVAC manufacturers to supply quality products.



Skilled Assembly Lines



Wind Tunnel Test Lab



Enthalpy Difference Test Lab



Burn In Test Lab



Cleanroom production lines for filters and air purification products



# COMFORT AND HEALTH

Din Ventilation offers customers a comprehensive, comfortable, and healthy air solution. Clients can easily and conveniently select appropriate products and solutions for their needs.

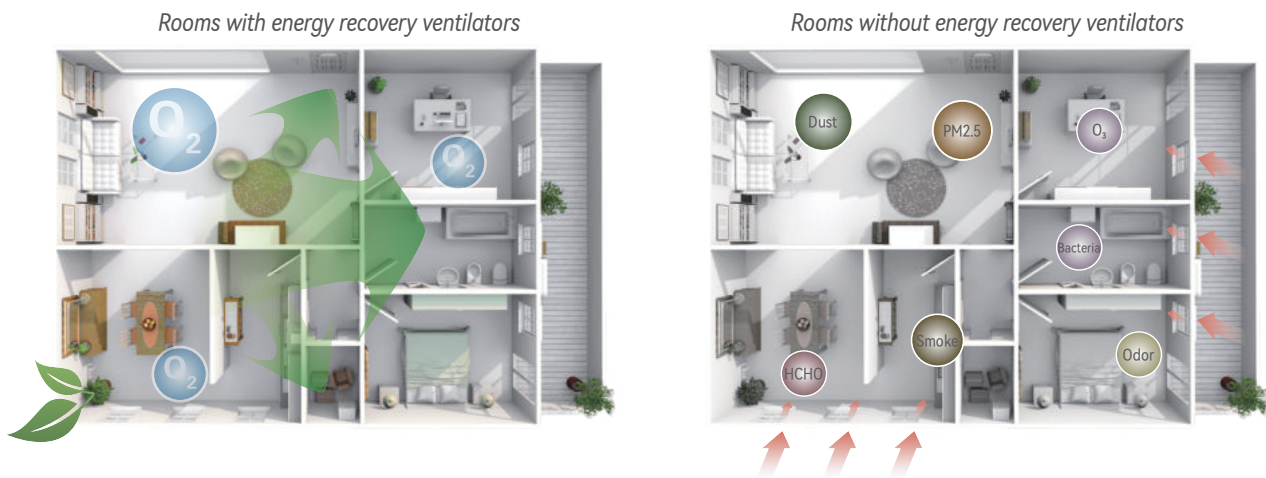

## AIR PURIFICATION

Studies have found that air purifiers can effectively remove indoor air pollutants, such as allergens, pollen, bacteria, and viruses, including COVID-19. The COVID-19 virus aerosols can linger in the air for up to three hours, making the chances of indoor airborne transmission 15-20 times greater than outdoors, particularly in inadequately ventilated buildings. Improved Version: Increased airflow and improved air filtration can decrease the amount of airborne particles from an infected person's cough or exhalation.

Some buildings only have natural ventilation or exhaust fans in bathrooms, but it's important not to overlook the air quality in the living and sleeping areas where people spend most of their time at home. If a building doesn't permit the installation of a mechanical energy recovery ventilation system because of budget or space constraints, air purifiers offer a more convenient and effective solution to routinely filter and sterilize indoor air as an alternative to mechanical ventilation.



## ENRICHED FRESH AIR

After renovation, indoor building materials, furniture, and adhesives may emit pollutants like radon, benzene, or formaldehyde, and the emissions can last up to ten years. Cooking fumes, secondhand smoke, mold, and odors are just some of the indoor sources that constantly threaten the health of those inside.

Fresh air systems accelerate indoor air circulation and effectively reduce indoor CO<sub>2</sub> levels by continuously introducing treated, fresh, clean, and comfortable air into indoor spaces. The positive pressure function prevents outdoor polluted air from infiltrating indoors through building gaps, while the bypass function allows for the enjoyment of outdoor natural air comfort during the spring and fall seasons. Some two-way ventilation systems with heat recovery capabilities can simultaneously introduce fresh air and expel indoor stale air outdoors, speeding up airflow, and reducing energy consumption.



## DEHUMIDIFICATION AND TEMPERATURE CONTROL

Din Ventilation' heat pump energy recovery ventilator combines full heat recovery with a DC inverter air conditioning system using patented technology, creating a unique two-way ventilation heat recovery system for customers. This system achieves whole-house air purification, dehumidification, and automatic adjustment of fresh air temperature. The coefficient of performance (COP) can exceed 6, providing more comfortable and energy-efficient air.

# ENERGY RECOVERY

Utilizing the cold or heat from the exhaust air to pre-cool or pre-heat the fresh air helps reduce energy consumption and improve indoor comfort for occupants. Airwood's patented heat recovery technology can achieve a heat exchange efficiency of up to **97%**.



## Cooling:

In summer, the ERV/HRV pre-cools fresh air from 37°C to 28°C and then introduces to indoor area, lowering the working capacity of AC system.

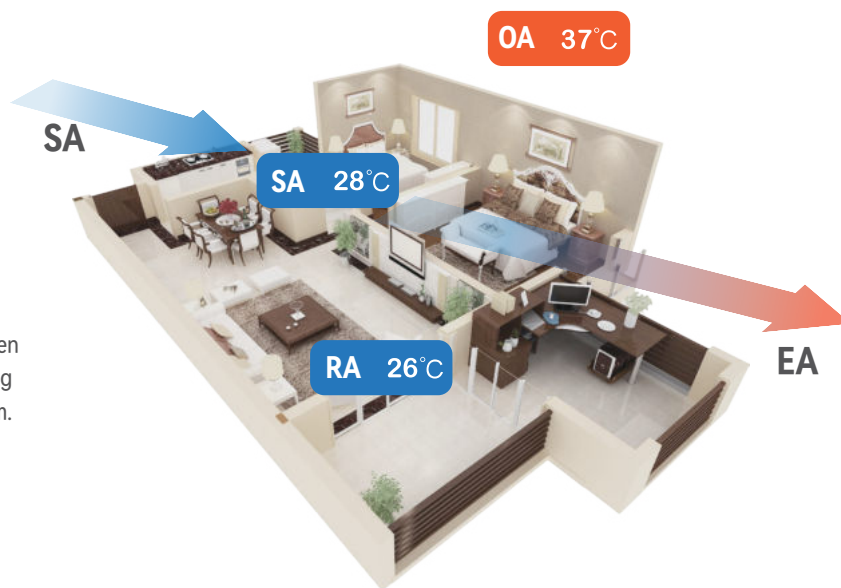

## Heating:

In winter, the ERV/HRV pre-heats fresh air from -5°C to 18°C and then introduces to indoor area, lowering the impact to indoor humidity.

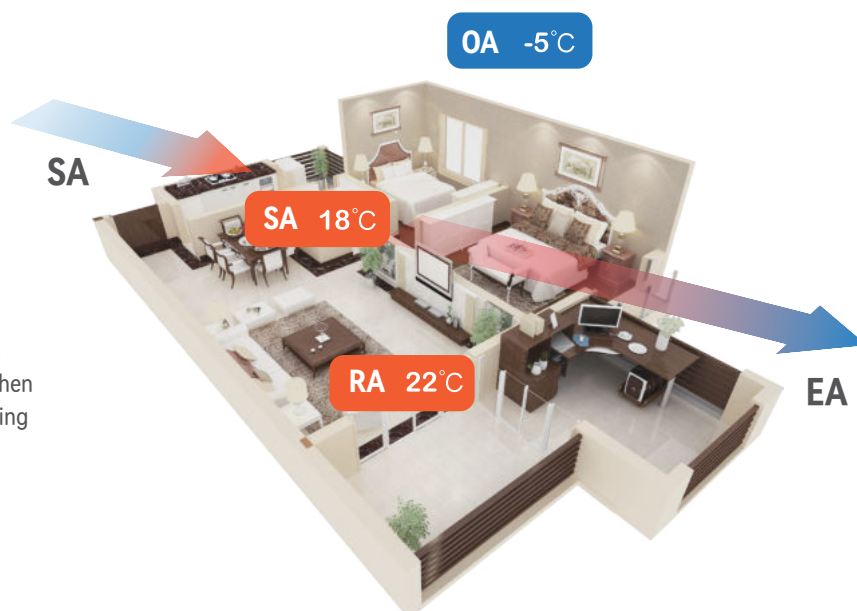



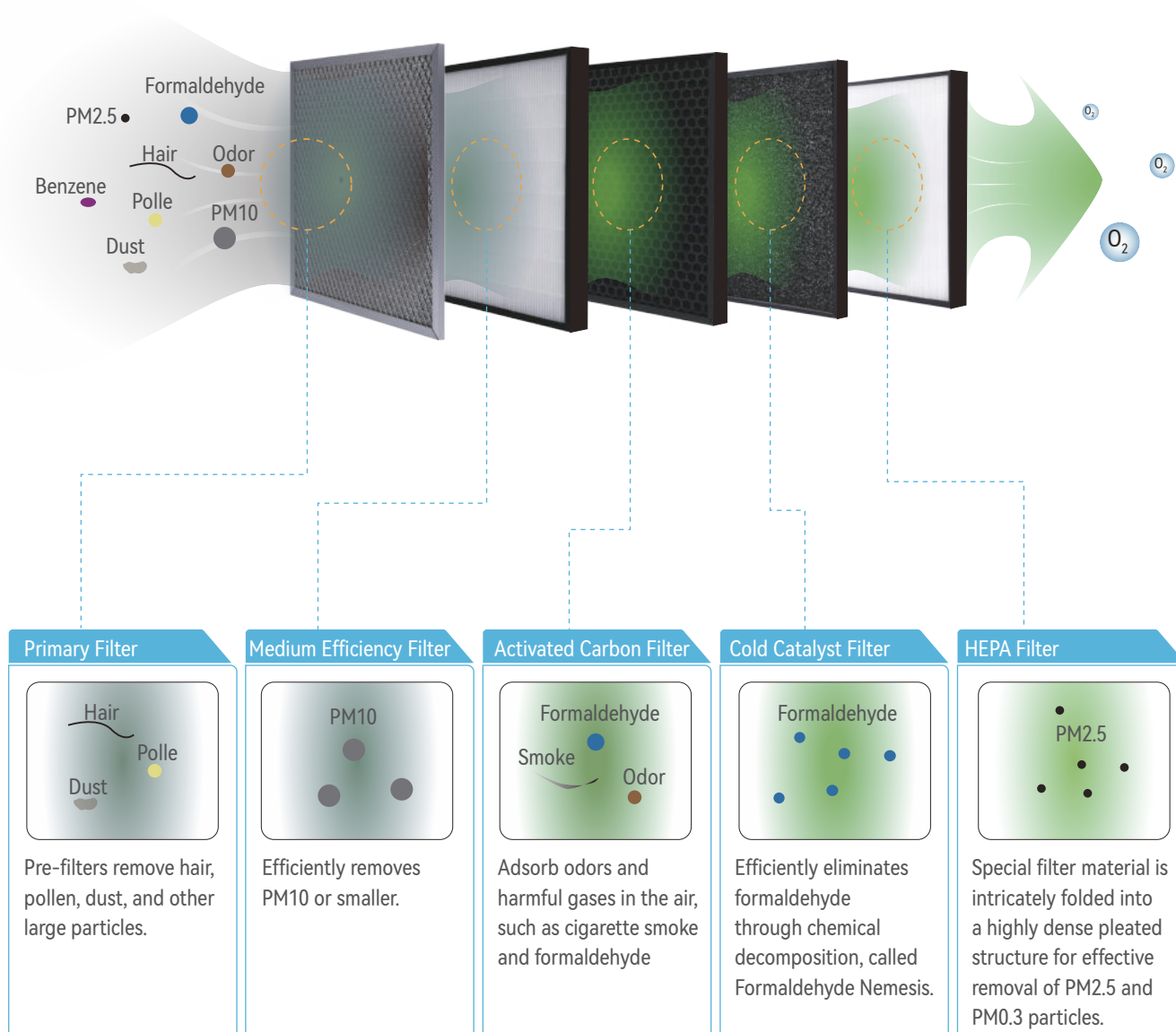

# MULTIPLE FILTRATION FOR OPTIONS

The rational combination and free configuration of pre-filters, medium-efficiency filters, activated carbon filters, cold catalytic converters, and high-efficiency filters effectively remove various pollutants and achieve a purification efficiency of over 99%. Simultaneously, it reduces system resistance and minimizes fan power consumption while achieving optimal purification outcomes.



\* The filter unit combination of the model is subject to the actual machine.

# PRODUCT RANGE OVERVIEW

Model	Installation Type	Main Features	Photo	Air Volume (m³/h)											
				0-100	150	250	350	500	650	800	900	1000	1500	2000	
Air Pro V2.0	Through Wall	R		[Green shaded area covering 0-100 m³/h]											
Air Duo	Wall Mounting	R		[Green shaded area covering 0-100 m³/h]											
Air School	Floor Standing	R							[Green shaded area covering 650-1000 m³/h]						
AirRes 250-500	Wall Mounting	R				[Green shaded area covering 250-500 m³/h]									
AirCeil 150-2000	Ceiling Mounting	R		[Green shaded area covering 150-2000 m³/h]											
Air comfort 350-900	Floor Standing	R P				[Green shaded area covering 350 m³/h]			[Green shaded area covering 650 m³/h]			[Green shaded area covering 900 m³/h]			

R Heat Recovery    
 H Heating    
 P Heat Pump System



**DIN VENTILATION**

**SINGLE ROOM**

# ENERGY RECOVERY VENTILATOR

Air pro V2.0

Suitable for  
**10~27** m<sup>2</sup>  
rooms



**97%** up to

Regeneration  
Efficiency



Elegant decorative front panel



Reversible fan with low energy consumption



Silent operation



Indoor air quality monitor



Mold prevention



F7 (MERV13) filter



Auto shutter to prevent air back drafting



Installation can be done internally and externally



Wireless pairing operation



Smart phone control Android /iOS

## WIRELESS OPERATION IN PAIR TO ENSURE BALANCED VENTILATION



No Extra Controller

No Wiring

No Impact On Decoration

\* Without blocked.

### CONTROL & FUNCTIONS



Timer



Weekly  
Schedule



Filter Alarm



Scene Control



Multiple  
Linkage Control



Free Cooling



Fan Boost  
Function



Smart Control According  
to Local Weather



Wireless  
Pairing Operation



Work with Alexa  
and Google Assistant



Group Control



Optional  
Negative Ion



Optional  
CO2 Control



Humidity  
Control



Download the APP for Din Ventilation at  
Google Play market and App Store.



Model	Air Pro V2.0
Voltage	100V-240V AC 50-60Hz
Air Flow in Supply/Exhaust mode(L/M/H)(CMH)*	20/40/50
Air Flow in Supply/Exhaust mode(L/M/H)(CFM)*	11.8/23.5/29.4
Input Power [L/M/L] (W)	6/7/7.8
Current (A)	0.06
Noise (1.5m) dB(A)	≤28.7
Max RPM	2200
Regeneration Efficiency (%)	≤97
Ingress Protect Rating	IPX4
SEC Class	A+
Diameter of Duct (mm)	158
Product Size (mm)	239.6x258x499.7 (The length of duct in wall is 220-500 mm)
Weight (kg)	4.2
WIFI Function	√
Humidity Sensor	√
F7 Filter (MERV13)	√

\* **Note:** The airflow of Air Pro V2.0 in supply/exhaust mode without F7 filter is about 34/56/70CMH or 20/33/41.2 CFM, and the relative parameters will be adjusted accordingly.

# INNOVATIVE HIGH EFFICIENCY

## Heat Storage Ball Regenerator



Din Ventilation as the leading manufacturer of single room energy recovery ventilator has developed the latest high efficiency heat storage ball regenerator, it's specially designed and gains higher efficiency and longer heat storage time compared with the traditional honeycomb ceramic regenerator.



- Washable
- Service life more than 10 years
- Higher heat exchange efficiency with more energy saving
- Adaptable to the trending single room ERV in the market
- Longer heat storage time
- Less temperature fluctuation
- More comfortable supply air temperature
- Patented innovative design
- Easy installation
- Customized design available
- Environment friendly

# Heat Exchange Performance Comparison

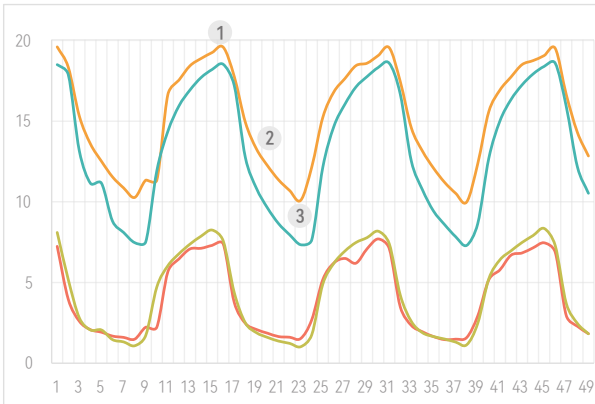

— Ball Regenerator SA temperature     — Honeycomb Regenerator SA temperature  
— Ball Regenerator OA temperature     — Honeycomb Regenerator OA temperature

- 1 At the peak of heat exchange, ball regenerator SA temperature is 1.5°C higher than the honeycomb regenerator.
- 2 Heat storage time lasts longer with less temperature fluctuation.
- 3 At the bottom of heat exchange, ball regenerator SA temperature is 2.5°C higher than the honeycomb regenerator.

# Heat Release Performance Comparison

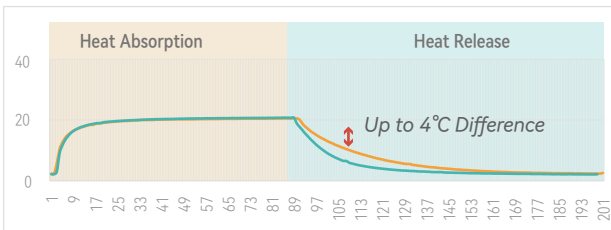

— Ball Regenerator     — Honeycomb Regenerator

According to our test, the heat absorption capacity is similar, while the heat release time of ball regenerator is longer, and the supply air temperature is higher than the honeycomb regenerator up to 4°C at the same releasing time.

# Dimensions

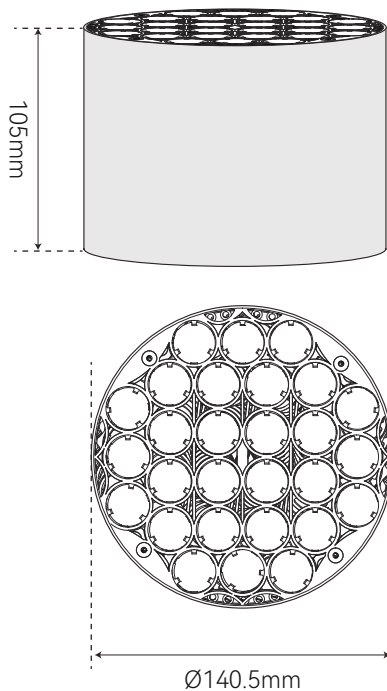

The Size of regenerator can be customized.

# Installation

The heat storage ball regenerator is installed in the inner pipe of single room energy recovery ventilator for heat exchange.

It's adaptable to the Din Ventilation Single Room Energy Recovery Ventilator.



Pipe Dia.

**110mm**

# Air Nano ENERGY RECOVERY VENTILATOR

**97%** up to

Regeneration  
Efficiency

✓ *Easy Installation with  
Small Hole of 120mm*

✓ *High Efficiency*

✓ *Quiet Operation*

✓ *Balance Ventilation*

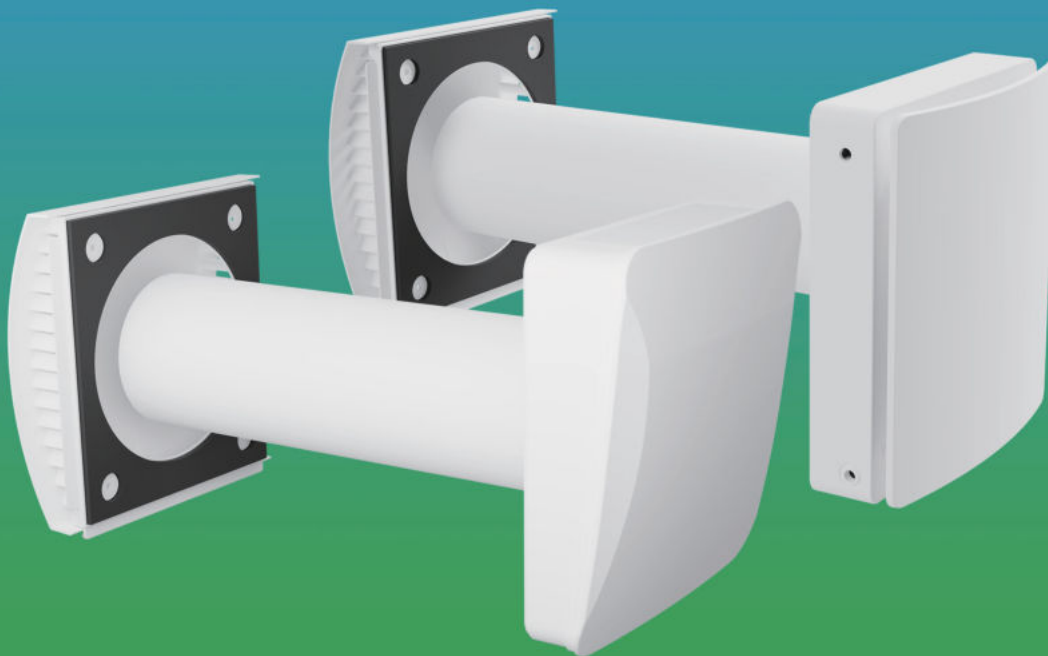

Elegant decorative  
front panel



Reversible fan with  
low energy consumption



Auto shutter to prevent  
air back drafting



Different outer hoods are  
optional for indoor installation



Humidity control



Wireless pairing operation  
function optional



Silent operation



F7 [MERV 13] filter optional



Mold prevention



WIFI function optional

## REVERSIBLE DC FAN

The reversible DC duct fan is characterised by its low power consumption and silent operation. The fan motor features built-in thermal protection and ball bearings for a long lifespan.



## AUTO SHUTTER

Auto shutter can prevent the insects entering and the cold air flowing backward when the unit stops.



## OPTIONAL WIRELESS PAIRING OPERATION

- Wireless control
- No extra controller
- No extra costs for installation
- No impact on existing decoration

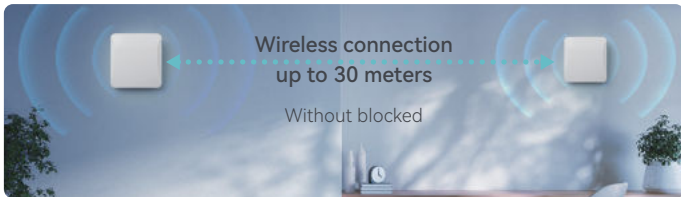

## OPTIONAL WIFI FUNCTION

The remote control is standard, while WIFI function is optional. It has the functions of running mode selection, fan speed control, filter alarm, backlight off, timer, weekly schedule, pairing operation and optional humidity control. It works with Tuya APP and can connect with Tuya network appliances.



## MODEL DESCRIPTIONS

Model	Picture	Functions			
		Humidity Control	CO <sub>2</sub> Control	WiFi Function	Pairing Operation
Air Nano		√	x	√	√

## TECHNICAL PARAMETERS

Voltage	100V-240V AC /50-60Hz	Sound Pressure Level (ISO3745-2012)	≤28.7 dB(A)
Air Flow in Supply/Exhaust Mode (L/M/H) (CMH)*	10/18/25	Regeneration Efficiency (%)	≤97
Air Flow in Regeneration Mode (L/M/H) (CMH)*	5/9/12	SEC Class	A+
Max Airflow (Under Fan Boost Mode) (CMH)*	30	Adaptable Wall Thickness (mm)	220~500
Input Power (L/M/H) (W)	4/5.6/7	Weight (kg)	3.5

**Note:** The airflow in supply/exhaust mode with F7 filter is about 8/11.5/16CMH, and the relative parameters will be adjusted accordingly.



**DIN VENTILATION**

# Air Mini ENERGY RECOVERY VENTILATOR

for Thin Wall Design



Suitable for wall  
**thickness > 15cm**

Suitable for  
**10~27 m<sup>2</sup>**  
rooms









**97%** up to

Regeneration  
Efficiency



**15** DOWN TO  
**CM**  
Adapts to Wall  
Thicknesses

## FEATURES

-  Elegant decorative front panel
-  Silent operation
-  Reversible fan with low energy consumption
-  Auto shutter to prevent air back drafting
-  Different panel/ outer hood design is optional
-  CO<sub>2</sub>/ humidity control
-  Wireless pairing operation
-  Mold prevention
-  Free cooling function

## Product Configurations

Model	Air Mini
Code	NCIE15
Suitable wall thickness (mm)	150-250
Honeycomb regenerator	×
High efficiency ball regenerator	✓
F7 (MERV13) filter	×
Primary filter	✓
CO <sub>2</sub> sensor	Δ
Humidity sensor	✓
WIFI function	✓
Wireless pairing function	✓
Remote control	✓
Multiple pairing operation	Δ
Negative ions function	Δ
Plastic hood	Δ
Metal outer hood	Δ

**Note:** "✓" Standard, "Δ" Optional, "×" Not available. Standard model doesn't include the outerhood.



Front Panel of White



Front Panel of Black



Metal Outer Hood



Plastic Hood

## Technical Parameters

Model	Air Mini
Code	NCIE15
Voltage	100V-240V AC /50-60Hz
Air flow in supply/ exhaust mode (L/M/H) (CMH)*	60/70/80
Air flow in supply/ exhaust mode (L/M/H) (CFM)*	35/41/47
Max airflow (under fan boost mode) (CMH)	85
Max airflow (under fan boost mode) (CFM)	50
Input power (L/M/H) (W)	7.9/10.8/12.1
Current (A)	0.063
Noise 3m dB(A)	≤39
Max RPM	2800
Regeneration efficiency (%)	≤97
Ingress protect rating	IPX4
SEC class	A
Diameter of duct (mm)	158
Product size (mm)	239.6×258×227.2 (The length of duct in wall is 150-250 mm)
Net weight (kg)	4.3

# ACCESSORIES

Picture	Accessory Name	Product Code	Picture	Accessory Name	Product Code
	Kit for the thin wall	DKAF-1		Heat storage ball regenerator	AS-TA50-2
	Extended pipe (Ø 160, Length 390 mm, to extend the total pipe length to 600 mm)	DVROER-1		Plastic hood	ADVUD-5/ DVUD-6
	Ventilation hood for indoor mounting	AS-VHI001		White painted metal outer hood for thin walls	DVUD-01
	Metal outer hood with electrical heater	AS-MHE001White/ AS-MHE001-B Black		Black painted metal outer hood for thin walls	DVUD-02
	Metal outer hood (white)	DVUD-3		F7 (MERV13) filter	DVFILTER-1
	Metal outer hood (black)	DVUD-2		Negative ions air purifier	AS-A5A

# AIR DUO

## ENERGY RECOVERY VENTILATOR



High efficiency heat and humidity recovery



Window mounting available without drilling holes



Innovative duct fan design



Remote control



Silent operation



Multiple installation options



Energy-saving DC motor



F7 (Merv 13) filter



EPP structure



Humidity monitor



Automatic bypass function optional



PM2.5 or CO<sub>2</sub> sensor optional

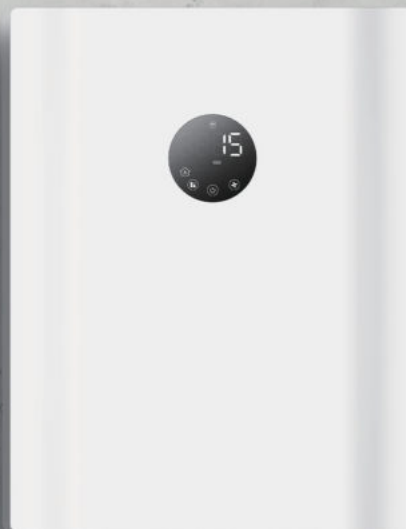

## ► MULTIPLE INSTALLATION OPTIONS

### Wall Mounted Installation

It can be mounted on the wall with two holes of 120mm, one for fresh air and other for exhaust air. It can be installed completely from inside without the need for any scaffolding on high buildings.



## ► CONTROL FUNCTIONS



Timer



Auto Mode



Energy Recovery Mode



Exhaust Mode



Manual Fresh Air Mode



PM2.5 Control Optional



Filter Alarm



Air Quality Monitoring



Negative Ion Function Optional



Humidity Display



CO<sub>2</sub> Control Optional



Multiple Linkage Control



Smart Control according to Local Weather



Work with Alexa and Google Assistant



Sleeping Mode



Scene Control



BMS Connection



Auto Bypass Optional



Model: Air Duo			
Rated Airflow (m <sup>3</sup> /h)	60/80/100	Product Size L*W*D (mm)	567*437*196
Airflow Under Sleep Mode (m <sup>3</sup> /h)	40	Power Supply	110-220V/50-60HZ/1ph
Temperature Efficiency (%)	75-90	N. W. (kg)	11
Enthalpy Efficiency (heating) (%)	67-75	Diameter of Duct (mm)	120
Enthalpy Efficiency (cooling) (%)	60-73	Working temperature (°C)	-20~40
Noise dB(A)	35	Filter	Coarse filter + F7 filter
Input Power (W)	28	Control	Touch Screen Panel / WIFI Control

# AIR SCHOOL

# ENERGY RECOVERY VENTILATOR



### Efficient Counterflow Heat Exchanger

Heat recovery efficiency up to 93% (washable, mold-resistant, and durable).



### EC Dual Inlet Fan

Wide airflow range (350-1000m<sup>3</sup>/h), energy-saving, and ultra-quiet (30-35dB(A)).



### Smart Control

Wi-Fi connectivity, touch screen, and real-time air quality monitoring via smartphone.



### PTC Auxiliary Heating

2200W PTC heating for quick and comfortable supply air temperature.









### Advanced Filtration

G4 + F8 filters (PM2.5 filtration >95%) , optional disinfection HEPA filter.



## ► DUCTLESS AND SILENT DESIGN

-  Ductless design
-  Quick and easy installation
-  Save on installation costs
-  No influence on the renovation of existing buildings
-  Large angle direct blowing for uniform air supply
-  Operation noise for low speed only 30 dB(A)



## ► PTC INTELLIGENT HEATING MODULE

— BUILT FOR EXTREME COLD

Many schools turn off ventilation in winter because it's too cold. We refuse to compromise.

Automatic defrost & smart heating: when outdoor temperature drops below  $-1^{\circ}\text{C}$ , the PTC heater activates automatically to prevent frost buildup and system shutdown.

Operates reliably even in temperatures below  $-25^{\circ}\text{C}$ .

Higher heating efficiency and greater safety, more energy-saving and durable than traditional heaters.

Adjustable supply air temperature — our LCD controller allows precise adjustment of both outdoor air (OA) and supply air (SA) temperatures, not just one.

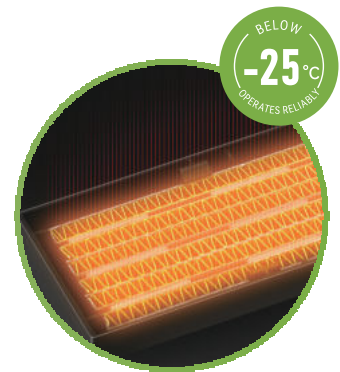

## ► HIGH-EFFICIENCY TOTAL HEAT EXCHANGER

— (COUNTERFLOW DESIGN)

- Our ultimate energy-saving solution.
- Heat recovery efficiency up to 93% — warm in winter, cool in summer, without high energy cost.
- Counterflow air paths maximize heat exchange and airflow smoothness.
- Ultra-low air resistance reduces power consumption.
- Antibacterial high-polymer membrane inhibits mold and bacteria, ensuring hygiene.
- Washable design extends lifespan beyond 10 years.

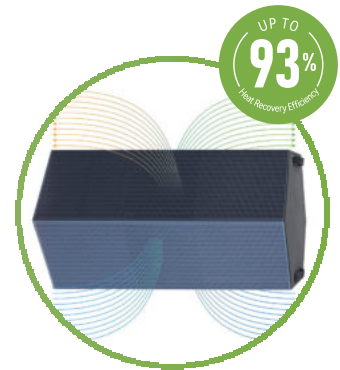

Model		Air School 700	Air School 900
Airflow (m <sup>3</sup> /h)		350-750	350-850
Enthalpy Efficiency (%)	Cooling	77-90	75-90
	Heating	69-83	66-81
Temperature Eff (%)		79-93	77-92
Noise dB(A) (at 1 meter at low speed)		30	30
Power Supply		220~240V/1Ph/50Hz	220~240V/1Ph/50Hz
Input Power (W)		340	350
Electrical Current (A)		1.55	1.6
Net Weight (kg)		135	140
Size (W*H*D)		650*1860*800	650*1860*800
Diameter of Duct (mm)		250	250



# AIRRES 250- 500 HEAT RECOVERY VENTILATOR

AirRes 250- 500 brings in outdoor fresh air and creates a healthy living environment with oxygen, comfortable temperature, and humidity. The efficiency of the built-in plastic counterflow heat exchanger is up to 95%. It is suitable to be installed in a cabinet, machine room, etc.. The constant EC fans supply a constant air volume, despite the filters are dirty. It is a perfect ventilation system for residential applications.

- 

Counterflow Heat Exchanger
- 

Efficiency up to 95%
- 

EC Constant Fans
- 

Left or right Installation
- 

Standard 100% Bypass
- 

Eco-design A or A+
- 

Enthalpy Exchanger Available
- 

EPP Structure
- 

Intelligent Control
- 

Android / IOS APP



► **FLEXIBLE INSTALLATION**

Left type or right type is optional. The installation type can be adjusted at site to meet different installation requirements.

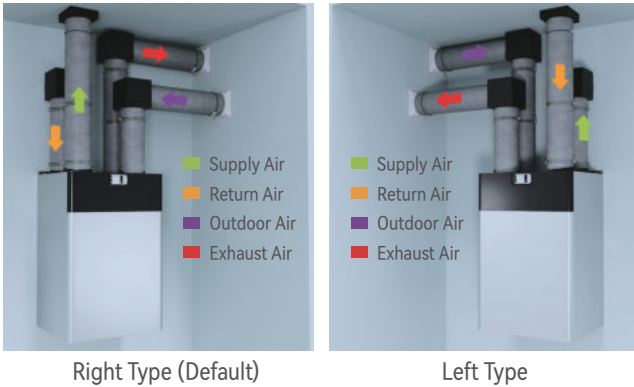

► **LOCAL CONTROL PANEL**

There are two control panels on the machine body. Panel 1 is for daily simple settings and Panel 2 is for advanced parameter setting.



► **CASING**

The internal structure is made by EPP material, which is light weight, heat preserve, silent, environmental friendly, no odor, etc. It has the good performance for air tightness and thermal insulation.



► **ENERGY EFFICIENCY CLASS OF A OR A+ ACCORDING TO EU NO. 1254/2014**

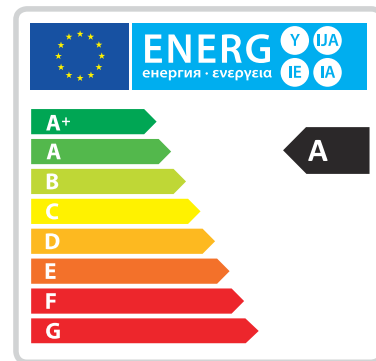

► **HIGH EFFICIENT CROSS COUNTERFLOW HEAT EXCHANGER**



Both sensible and enthalpy cross counterflow heat exchanger are available.

► **EC CONSTANT AIRFLOW FANS**

Application of the unique constant airflow fans guarantees the preset air flow rates and the balance between supply and extract air. Balanced ventilation always guarantees high efficiency, independent of the resistance in the duct system or dirty filters. It also saves time when commissioning the system.



Model	AirRes 250	AirRes 350	AirRes 500
Rated Airflow (m³/h)	250	350	500
External Pressure (Pa)	130	150	160
Max. Temperature Efficiency (%)	95	95	95
Noise dB(A)	35	37	39
Voltage (V)	230	230	230
Max. Power (W)	137	272	412
Diameter of Duct (mm)	144	144	196
Product Size (mm)	595*480*975	595*480*975	655*625*1085
N.W. (kg)	40	40	50



# AIRCEIL-150 TO AIRCEIL-2000 ENERGY RECOVERY VENTILATOR

AirCeil-150 to AirCeil-2000 energy recovery ventilator is a new ventilation device that integrates air filtration and energy recovery. Composed of heat exchangers, filters, plastic-encapsulated DC fans and intelligent control system, it can effectively improve indoor air quality, increase indoor oxygen content, and at the same time greatly reduces the power load of indoor air-conditioning equipment, with high efficiency and energy saving.



DC Fan



10 Speeds



High ESP



Auto Bypass



5th Generation  
Heat Exchanger



New EPS Inner  
Structure



Optional  
SA/EA Air  
Direction



Occlusal  
Edge Sealing  
Technology



Intelligent  
Control



Wifi and IOT



### ▶ PLASTIC-ENCAPSULATED DC FANS

The AirCeil series ERV is built in plastic encapsulated brushless DC motors, which have higher processing precision and stable operation.

Compared with a traditional DC motor, the energy saving is up to 40%, resulting in lower power consumption, larger air volume, and higher ESP.



### ▶ NEW EPS INNER STRUCTURE

Good thermal insulation, sealing, and Occlusal edge sealing technology, stronger casing strength, greatly reduce the screws, and improve the appearance.

Central fans design make a better distribution of supply air and exhaust air, heat exchange of the core is more efficient.

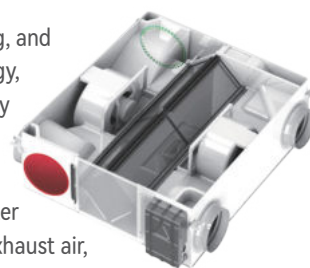

### ▶ NEW PROCESSING TECHNOLOGY

Occlusal edge sealing technology, stronger casing strength, greatly reduce the screws, and improve the appearance.

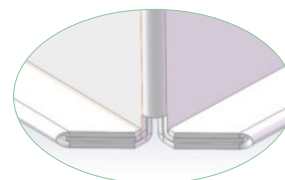

### ▶ THE 5TH GENERATION ENTHALPY HEAT EXCHANGERS

5th generation thinner membrane, with better thermal conductivity and higher heat exchange efficiency. Resin installation rail, simple structure, good sealing performance. Integrated with primary filters and an optional medium filter installation rail.

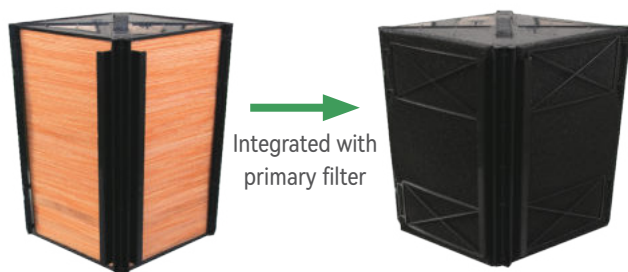

### ▶ ENERGY EFFICIENCY CLASS OF A OR A+ ACCORDING TO EU NO. 1254/2014

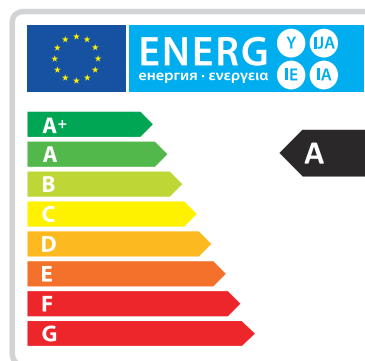

Model	AirCeil 150	AirCeil 250	AirCeil 350	AirCeil 500	AirCeil 650	AirCeil 800	AirCeil 1000	AirCeil 1500	AirCeil 2000	
Rated Airflow (m <sup>3</sup> /h)	150	250	350	500	650	800	1000	1500	2000	
External Pressure (Pa)	95	85	160	120	120	150	170	175	150	
Enthalpy Efficiency (%)	Cooling	71-79	68-83	71-82	67-82	66-81	70-81	71-86	71-81	71-86
	Heating	73-79	70-83	72-84	69-83	69-82	71-82	73-87	72-82	73-87
Temperature Efficiency (%)	80-84	79-86	80-89	78-87	77-86	79-85	80-90	80-85	80-90	
Noise dB(A)	29	28	32	34	35	35	37	39	40	
Diameter of Duct (mm)	100	150	150	200	200	250	250	289*718	289*718	
Product Size (mm)	610*780*289	735*780*289	874*884*331	1016*884*331	954*908*404	1004*1144*404	1231*1144*404	1004*1144*808	1231*1144*808	
Voltage (V)	220-240	220-240	220-240	220-240	220-240	220-240	220-240	220-240	220-240	
Input Power (W)	58	62	140	165	252	335	420	670	850	
N.W. (kg)	20	23	30	33	38	48	54	105	117	

PORTABLE

# AIR IONIZER

- ▶ Filterless
- ▶ Negative ions up to 130 million /cm<sup>3</sup> at air outlet
- ▶ Built in dual voltage power supply
- ▶ Quick air purification and deodorization
- ▶ Make you breath forest-fresh air



## Advanced Ionization Technology

Negative ions eliminate airborne germs, bacteria, or pollutants.



## Easy to Use

Connect with ease to your phone charger or any USB outlet.



## Sleek Design

Compact, portable. Various light color lets you know it working!



## Efficient

Low noise + low energy consumption.

## How does it work?

Air Ionizer works to clean your air by method of negative ionization.

In high enough concentrations, negative ions clear the air of pollutants.

Research from the United Nations has confirmed that ecological-grade negative ionizers can actively capture small particles of dust, causing them to condense and precipitate, effectively removes fine dust 2.5 microns (PM2.5) and smaller particles in the air. The smaller the diameter of the flying dust, the easier it is to be precipitated by negative ions.







Here are the test results showing the removal rate of PM2.5 and bacteria by Air Ionizer.



**UPTO**  
Bacterial  
(*Staphylococcus albus* 8032)  
Killing Rate  
**99.53%**

**UPTO**  
**92.37%**  
PM2.5 Purifying Efficiency

► **FUNCTIONS**

-  Blue Breathing Light: **Sleep Mode**
-  Green Breathing Light: **Negative Ion Mode**
-  Red Breathing Light: **Low Battery Warning (<20%)**
-  Blue Light Flashes 3 Times: **Charging in Progress**
-  Steady Green Light: **Fully Charged**
-  Steady Blue Light: **Charging While Off**



► **OPERATION GUIDE**

**Startup & Mode Switching**

- Long press the power button for 3s to power on/off.
- In power-on state, short press the power button to switch sleep mode or negative Ion mode
- Short press the light button to toggle the indicator on/off.

**Charging**

- Red breathing light flashes when battery level <20% (charging required).
- Charging during operation: blue light flashes 3 times, then resumes previous mode.
- Charging when powered off: blue light flashes 3 times, then stays steady.
- Steady green light indicates full charge.



Model: Air Ionizer	
Working Environment Temperature	-10°C to 60°C, R.H.≤ 80%.
Working Voltage	DC 12V
Input Voltage	DC 5V
Power	0.85W
Current	0.23A
Battery Capacity	3500mAH
Battery Life	≥10H
Net Weight	220g
Product Size	80mm×80mm×58mm

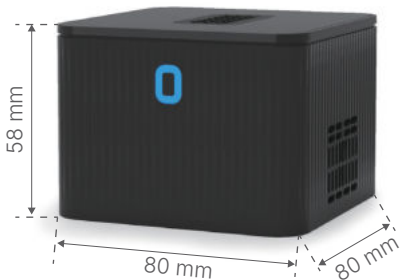

► **APPLICATIONS**

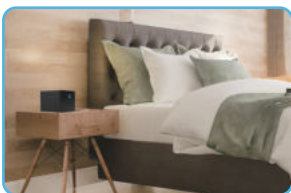

Bedroom



Living Room



Office



Car

# HPERV *DC INVERTER*

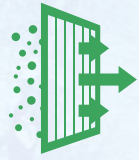

Purification



Fresh Air  
Energy Recovery



Cooling/ Heating



Dehumidification



Suitable for  
**500~6,500**  
sq.ft

Airflow from  
206-559 CFM



## CONTROL & FUNCTIONS

- 10-speed control
- Auto bypass
- Temperature control
- Humidity control
- Defrosting
- Filter replacement alarm
- Fault alarm
- RS485 connector
- Auto restart
- Weekly timer
- Multiple signal connectors
- Smart control according to local weather
- Work with Alexa and Google Assistant
- Scenario control
- Group control
- Multiple linkage control
- Optional CO<sub>2</sub> control

Download the **Din Ventilation** App at Google Play or APP Store.



## TECHNICAL PARAMETERS

Model		Air comfort 350	Air comfort 650	Air comfort 900
Rated Airflow	CMH	350	620	950
	CFM	206	365	559
Exhaust Airflow (Ventilation Mode)	CMH	350	620	950
	CFM	206	365	559
Exhaust Airflow (Heating/Cooling Mode)	CMH	350	620	950
	CFM	206	365	559
External Static Pressure	Pa	100	100	100
	In.w.g.	0.4	0.4	0.4
Ventilation Mode	Temperature Efficiency (Heating)	%	77	77
	Temperature Efficiency (Cooling)	%	72	72
	Enthalpy Efficiency (Heating)	%	76	77
	Enthalpy Efficiency (Cooling)	%	70	65
	Input Power	W	185	451
	Input Current	A	1.67	3.77
Cooling/Heating	Nominal Cooling Capacity	Kw	3.798	6.394
		kcal/h	3,265.690	5,497.850
		Btu/h	12,959.310	21,817.220
	Max Cooling Capacity	Kw	4.173	6.946
		kcal/h	3588.112	5972.449
		Btu/h	14238.860	23700.724
	Input Power (Cooling)	W	847	1243
	Operation Current (Cooling)	A	4.43	6.55
	EER	-	4.48	5.14
	Nominal Heating Capacity	Kw	4.631	6.287
		kcal/h	3981.942	5405.846
		Btu/h	15801.620	21452.124
	Max Heating Capacity	Kw	4.981	6.921
		kcal/h	4282.888	5950.987
		Btu/h	16995.869	23615.421
Input Power (Heating)	W	790	1033	
Operation Current (Heating)	A	3.91	5.74	
COP	-	5.86	6.09	
Noise	dB(A)	37/42	40/44.6	41/46
Power	-	230V 1P 60Hz	230V 1P 60Hz	230V 1P 60Hz
Dimension (W×L×H)	mm	600×760×1010	740×1050×990	740×1090×1130
	Inch	23.6×30×40	29×41×39	29×43×44.4
Weight	Kg (lbs)	135 (297.62)	165 (363.76)	195 (429)
Air Inlet/Outlet Diameter	mm (Inch)	195 (7.68)	245 (9.65)	245 (9.65)
Air Inlet/Outlet Height	mm (Inch)	40 (1.57)	40 (1.57)	40 (1.57)
Machine Base Height	mm (Inch)	40 (1.57)	40 (1.57)	40 (1.57)
Drainage Pipe	-	G1/2 21mm (0.827Inch)	G1/2 21mm (0.827Inch)	G1/2 21mm (0.827Inch)
Refrigerant	-	R32	R32	R32
Refrigerant Charge	g	370	500	660

# COMING SOON

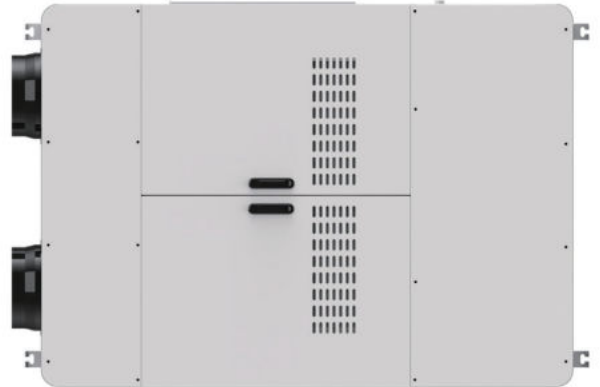



**DIN VENTILATION**

[kontakt@dinventilation.dk](mailto:kontakt@dinventilation.dk)  
Valhøjs alle 158, 2610 rødovre, Denmark  
[www.dinventilation.dk](http://www.dinventilation.dk)

Din Ventilation reserve the right to make any modifications to product specifications or any other details, without prior notification.